

# L. B. CLOGSTON. Stone-Turning Lathe.

No. 224,150.

Patented Feb. 3, 1880.

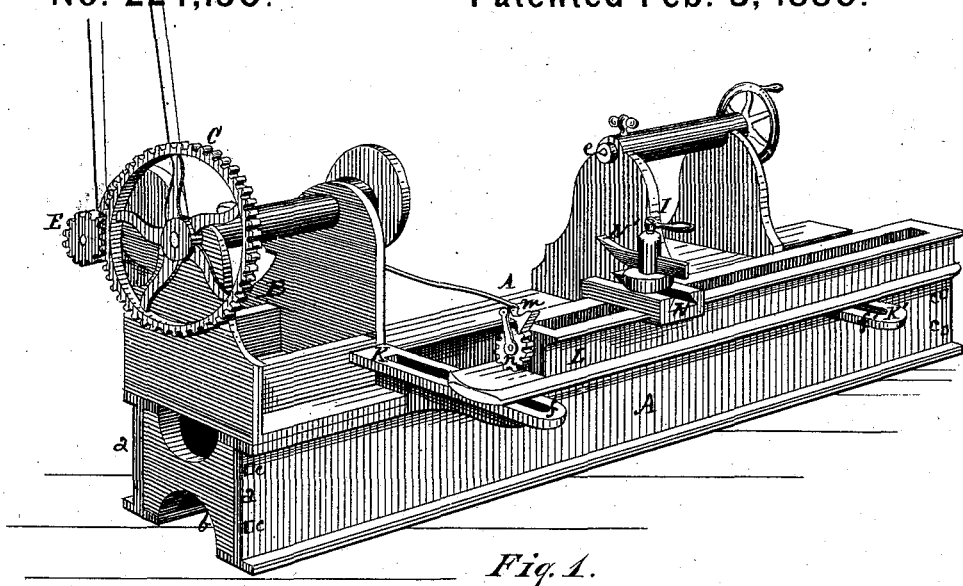

Fig. 1.

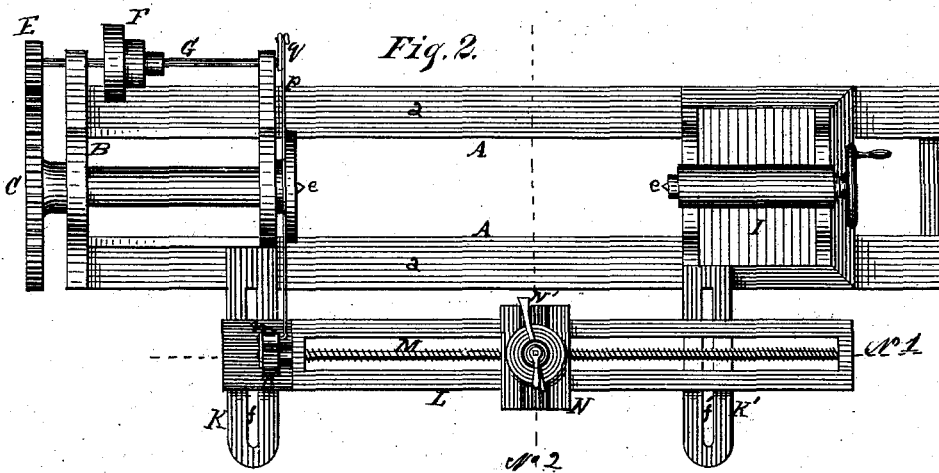

Fig. 2.

Witnesses. {  
 Dexter Reynolds.  
 Wm. H. Hailes

Lucius B. Clogston

Inventor.  
 per Alex. Selkirk  
 City for Clogston

L. B. CLOGSTON.  
Stone-Turning Lathe.

No. 224,150.

Patented Feb. 3, 1880.

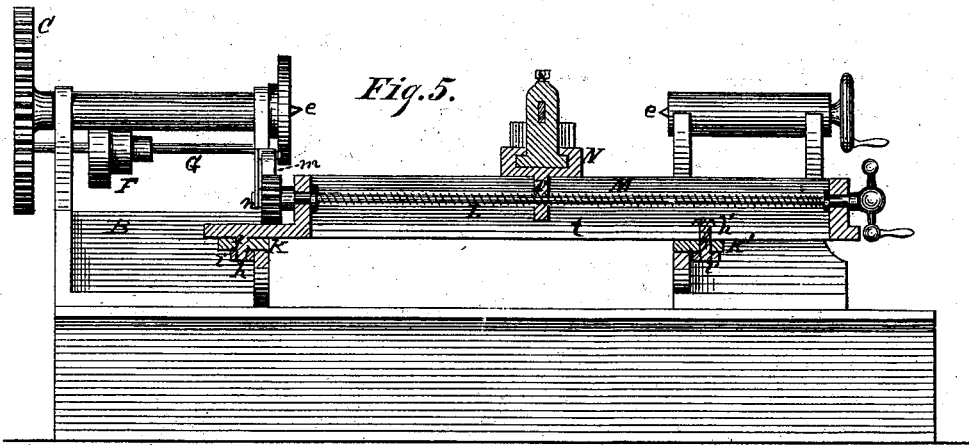
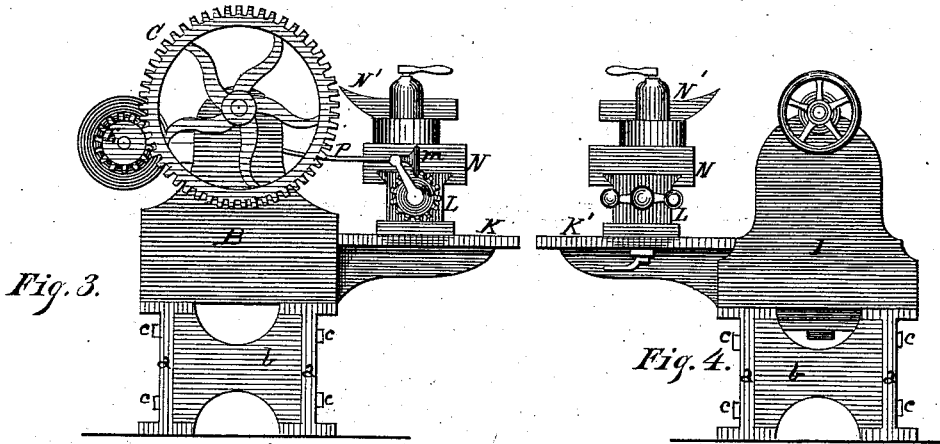

Witnesses. { *Dexter Reynolds.*  
*Wm. H. Hailes*

*Lucius B. Clogston*  
 Inventor.  
*per Alex. Selkirk*  
*att'y for Clogston*

L. B. CLOGSTON.  
Stone-Turning Lathe.

No. 224,150.

Patented Feb. 3, 1880.

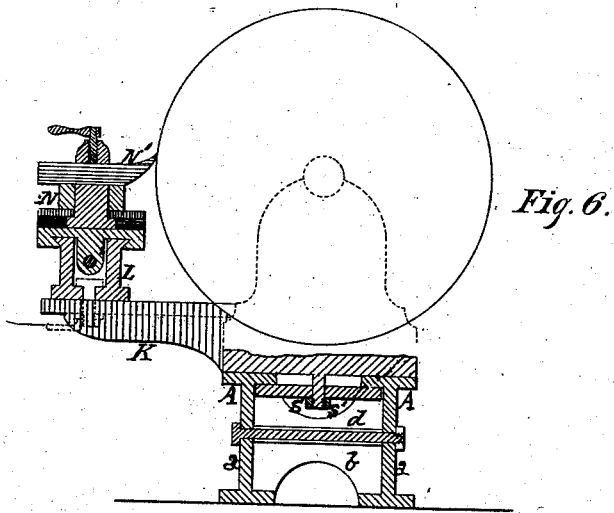

Witnesses. { Dexter Reynolds.  
Wm. H. Hailes

Lucius B. Clogston  
Inventor.  
per his Attorney  
C. H. S. S. S.

# UNITED STATES PATENT OFFICE.

LUCIUS B. CLOGSTON, OF FAIR HAVEN, VERMONT.

## STONE-TURNING LATHE.

SPECIFICATION forming part of Letters Patent No. 224,150, dated February 3, 1880.

Application filed June 17, 1879.

To all whom it may concern:

Be it known that I, LUCIUS B. CLOGSTON, of Fair Haven, Rutland county, in the State of Vermont, have invented a new and useful Improvement in Stone-Turning Lathes, which improvement is fully described in the following specification and accompanying drawings, in which—

Figure 1 represents a perspective view of the improved lathe. Fig. 2 is a plan view of the same. Fig. 3 is an end view of the same from its head end. Fig. 4 is an end view from the tail end. Fig. 5 is a sectional elevation taken at line No. 1 in Fig. 2. Fig. 6 is a cross-sectional view taken at line No. 2 in Fig. 2.

The invention relates to lathes for turning cylinders of stone; and it consists in the combinations and arrangements of parts hereinafter more particularly described and set forth, whereby blocks or shafts of stone of different diameters, with either straight or tapering or irregular forms, may be readily and easily turned, and with a uniformity of surface, whether the stone be of equal or unequal hardness in its parts; also, whereby the block of stone to be turned may be easily mounted and properly swung in the lathe without disturbing the operating parts of the same, and also whereby the chips and grit incidental to the cutting of stone will be prevented from wearing the grinding or moving parts of the lathe, while the several parts of the lathe may be quickly and accurately adjusted for operation with blocks of longer or shorter lengths, or larger or smaller diameters, for turning straight shafts, or shafts of greater or less tapering sides.

In the drawings, A A represent the bed of the lathe, which is formed of wrought-iron I-shaped beams *a a*, extending from end to end, and struts *b b*, made of cast-iron, and secured by bolts *c c*, as shown in Figs. 3 and 4, and stiffened with one or more stays placed at the middle of the length of the said bed, or at several points (as with stay *d*, shown in Fig. 6) between the end struts, *b b*. With this mode of construction of the lathe-bed, the side pieces, *a a*, being made of wrought-iron, and of usual merchantable form, with maximum of strength attending a minimum of weight of metal, I am enabled to dispense with the labor and cost at-

tending the making of patterns necessary to be used when cast-iron is employed for making the bed, as heretofore made, while at the same time I greatly reduce the weight of the metal and absolutely free the bed from all liability of its being broken by any sudden blow or fall of a stone when rolled or moved suddenly against it.

B is the head-stock, made of cast metal, with the usual gear for revolving the mandrel and face-plate.

The gear C is revolved by the small gear E, fixed to shaft G, which carries a cone-pulley, F. At the end of shaft G opposite from the small gear E is a crank and wrist-pin, *q*, which, revolved by shaft G, works the rod *p* and gives motion to the dog *m*, Figs. 2, 3, and 5, for imparting to the ratchet-wheel *n* an intermittent movement.

Cast with or securely attached to the head-stock is the bracket-arm K, provided with a vertical slot, *f*, in its upper side, and running outward from the head-stock at right angles with the same, as shown in Figs. 1 and 2.

I is the tail-stock, made of cast-iron and carrying the tail-screw with center-pin *e*, as is the practice of the trade. Cast solid with the said tail-stock, or securely connected therewith, is the bracket K', provided with slot *f'*, similar in form and size as slot *f* in bracket K.

L is the tool-stock way, supported on brackets K and K' at a greater or less distance from the side of the lathe-bed  $\Delta$ , as shown in Figs. 2, 3, 4, and 6. The said tool-stock way is secured in place either nearer to or farther from the lathe-bed, according to the diameter of the stone to be turned, by the bolt *h* and nut *i*, Fig. 5, at the head end of said tool-stock way, and bolt *h'* and nut *i*, passing through a slot made in the lower side or bottom of the said way, as shown in the same figure. Working in the tool-stock way is the feed-screw M, running longitudinally from end to end thereof, as shown in Figs. 2 and 5. The head end of the said feed-screw is fixed to the ratchet-wheel *n*, and is revolved by the dog or pawl *m*.

N is the tool-holder, made with any of the usual forms known to the trade which will be best adapted to operate with the way it moves on and steadily carry the tool N'. The said tool holder or stock is provided with a bracket

or arm, *r*, provided with a screw-threaded hole which receives the feed-screw *M*, which screw, when revolved, carries the tool-stock with its cutting-tool in either direction, according to the direction the said feed-screw is revolved by the dog or pawl operating with the ratchet *n*. The tail end of the feed-screw is provided with a hand wheel or crank for revolving the feed-screw by hand when desired.

The manner in which this improved lathe is operated is as follows: In placing and fixing the stone to be turned in the lathe the stone is introduced between the head and tail stocks from the side opposite from the tool-stock way, and the tail-stock only is to be moved nearer to or farther from the head-stock, accordingly as the length of the stone will require. The head-stock is secured in place on the bed of the lathe by bolts, and the tail-stock is secured to its place on said bed by the cross-bar *s* and bolt and nut *s'*, Fig. 6, so as to be readily loosened and moved at any distance required on the lathe-bed. The head end of the tool-stock way is to always remain at the same place, so that the mechanism working the feed-screw will always be in the same working position and condition. When the tail-stock is moved over the bed of the lathe in either direction the bracket-arm *K'* will be carried with it, and the bolt *h'*, securing the tail end of the tool-stock way to the said bracket, will be moved in the slot *t*, Fig. 5, of the said way. If the stone is to be turned with straight parallel sides the tool-stock way will be so secured in relation to the bed of the lathe as to be at equal distances apart from centers to centers, uniformly, of said lathe bed and tool-stock bed. When the stone is to be turned with a tapering form the end of the tool-stock way toward the tail end of the lathe is to be set nearer to or farther from the lathe-bed than its head end, according as it is intended the taper is to run.

Power is to be applied to some one of the pulleys of cone-pulley *F*, which when revolved will revolve the gear *C* and the face-plate and center *e*, which engages with the stone for revolving the same. When the cone-pulley *F* is revolved it will, through shaft *G*, revolve the crank *q*, and give a reciprocating movement to the rod *p*, which will give a vibratory movement to the double dog or pawl *m* and cause it to engage with the ratchet-wheel *n*, attached to the feed-screw *M*, and revolve the same, and cause the tool-holder *N* to be moved over the way, and carry the cutting-tool *N'* along from one end of the lathe to the other.

It will be readily seen that the change of material made by me in the metal employed for the lathe-bed secures to the said bed a strength that could not be secured by the use of cast-iron as heretofore, and that by employing wrought-iron of the form shown and described the sudden fall of a heavy stone will not break the same, and by being constructed with the struts and braces described all liability of the side pieces being bent or deflected is prevented.

It will also be seen that by placing the tool-stock way off at one side from the lathe-bed, as shown and described, a stone can be properly placed and swung without necessitating the removal of the tool-holder, and that the chips and cuttings of the stone will fall clear of the way the tool-holder moves on, so that it will always be free from that excessive wear to which the ways are subjected in lathes for cutting stone as heretofore made.

It will also be readily seen that with the head-stock and its adjunctive parts being always at the same place, and the tail block or stock only movable on the lathe-bed, while the tool-stock way is situated to one side and off from the said lathe-bed, with its head end secured from a longitudinal movement, while its tail end may be relatively adjusted with the tail-stock toward or from the same, all necessity for adjusting either the head-stock or tail-stock for producing a tapering shaft, as was heretofore required, is avoided, and the adjustment of the tool-stock way for producing tapering forms can be more readily and accurately made.

It will also be readily seen that by combining the brackets *K K'* to their respective head and tail stocks, and out at right angles with the same, and providing feeding mechanism connected with the tool-stock way, (for moving the tool-holder,) secured to the said brackets, as described, the feed mechanism will always be in a proper position for carrying the tool, and be readily adjusted, and that the parts of the feeding mechanism will not become excessively worn.

It will also be readily seen that the tool-stock way can be at all times readily adjusted, so as to be parallel with the centers *e e*, or oblique with the same, and be firmly secured without changing the stone when once swung.

Having described my invention, what I claim, and desire to secure by Letters Patent, is—

1. In a lathe or machine for turning stone, the bed *A A*, constructed of wrought-iron *I*-shaped beams and end struts, secured together and braced substantially in the manner set forth, for the purpose specified.

2. The combination, with the bed, head-stock and tail-stock of a lathe or machine for turning stone, of a tool-stock way situated at one side of said head and tail stocks and laterally off from the said bed, substantially in the manner set forth, for the purpose specified.

3. The combination, with a fixed head-stock having mechanism for revolving the face-plate and a movable or adjustable tail-stock, in a machine for turning stone, of a tool-stock way situated laterally off from a side of said head and tail stocks, with its head end secured from a longitudinal movement and tail end admitting an adjustment toward or from the tail-stock, in the manner and for the purpose set forth.

4. In a machine for turning stone, the combination, with a fixed head-stock and an adjustable tail-stock, of brackets *K K'*, projecting outward from the said head and tail stocks

and past the side of the bed of an adjustable tool-stock way provided with feeding mechanism for moving the tool-stock, substantially as and for the purpose set forth.

5 5. In a machine for turning stone, the combination, with a fixed head-stock, provided with mechanism for revolving the face-plate, and a tail-stock capable of being set nearer to or  
10 farther from the said head-stock, with their centers  $e e$  on the same horizontal plane, of a

tool-stock way having a feed mechanism for moving the tool-stock and adapted to be adjusted parallel with the axis of the centers  $e e$ , or relatively oblique with the same, substantially as and for the purpose set forth.

LUCIUS B. CLOGSTON.

Witnesses:

H. D. BACON,  
ALEX. SELKIRK.